

- N.B:** (1) Question No.1 is compulsory.
 (2) Solve any three questions from the remaining five.
 (3) Figures to the right indicate full marks.
 (4) Assume suitable data if required and mention the same in the answer sheet.

Q.1) Solve any four :

a) Derive the voltage gain of the circuit shown in fig 1.a. Assume I_0 is ideal.

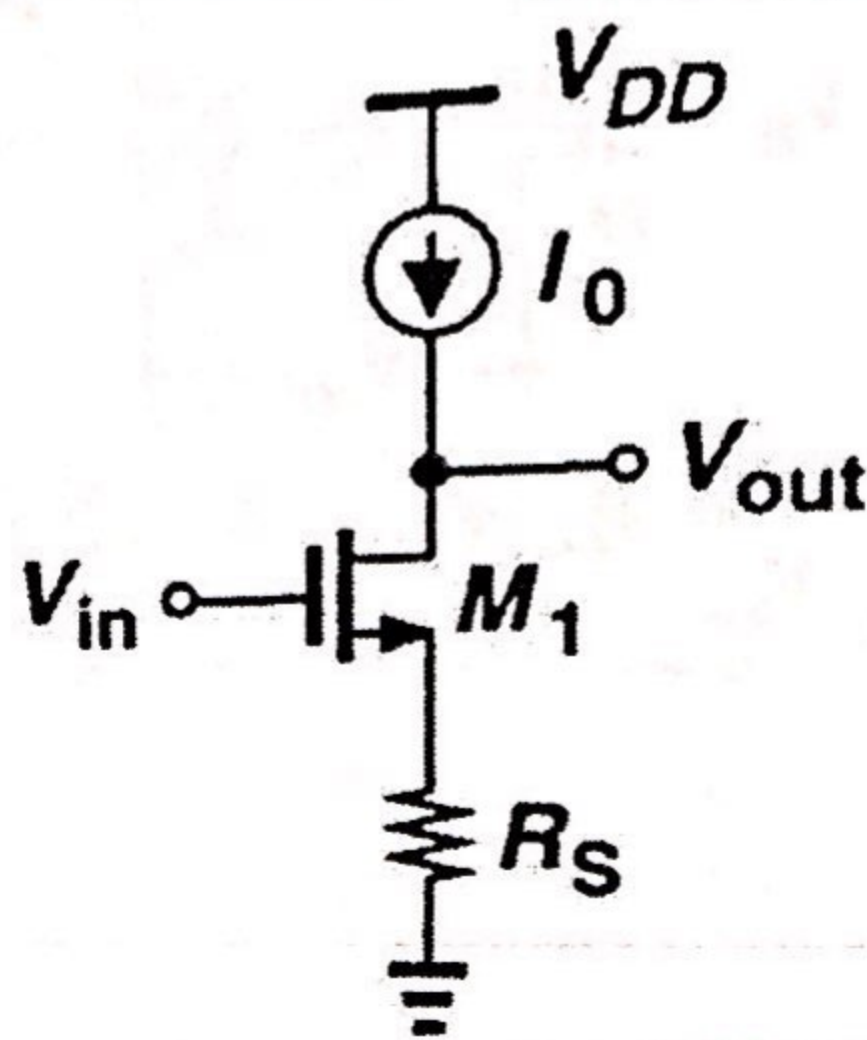

Fig.1a

- b) Derive for total output noise voltage of common source stage with passive load R_D and no source resistance.
- c) Draw a Simple circuit to establish supply independent current. How can body effect be eliminated in this circuit?
- d) Explain working of unity gain sampler circuit.
- e) How thermal noise is modeled in MOSFET?
- 2) a) Draw CMOS differential amplifier using p-channel input MOSFET. Find highest common input Voltage, $V_{IC}(\max)$ and lowest common input voltage $V_{IC}(\min)$. 10
- b) Explain miller compensation technique with respect to two stage OTA. 10
- 3) a) Explain the design procedure for cmos cascode amplifier to achieve target specification like, Small signal gain A_v , Maximum and minimum output voltage swings and power dissipation P_{diss} for given supply voltage V_{DD} . 10
- b) Explain the various trade-off in analog design with the help of Analog octagon. 10

TURN OVER

- 4) a) Explain in detail working of switched capacitor integrator. 10
 b) Assume the device in fig 2 operate in saturation and circuit is symmetric, derive the expression for input referred noise voltage. 10

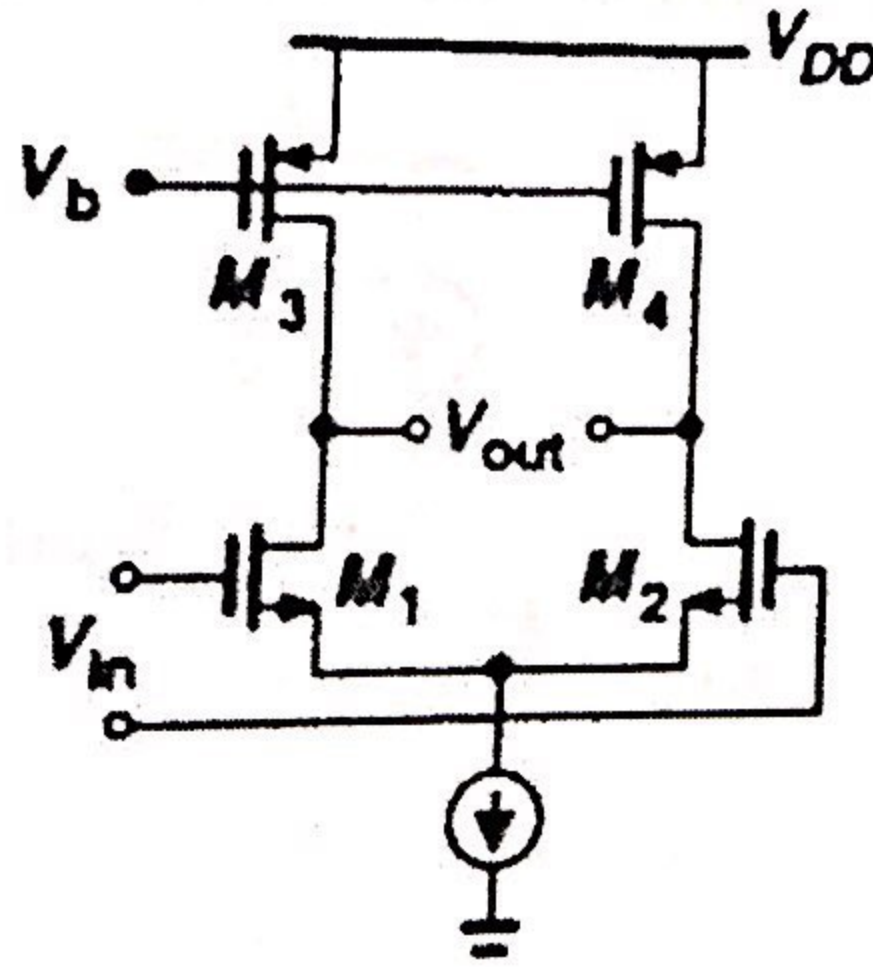

Fig.2

- 5) a) Explain in detail working of 2 step flash ADC. 10
 b) Explain with the help of neat diagram of CMOS band gap reference generator and derive the Expression for its output voltage. 10
- 6) Write short notes on any four : 20
- a) Pipelined ADC
 - b) Active current mirror
 - c) Mixed signal layout issue
 - d) Switched capacitor integrator
 - e) Noise representation in MOSFET circuit

Duration: 3 Hours

Marks: 80

Note:

- 1) Q.1 is compulsory.
- 2) Attempt any three questions from the remaining five questions.
- 3) Assume Suitable data wherever necessary

Q1. Answer any four

20

- a) What are different security goals? Describe various attacks compromising these goals.
- b) State Fermat's Little Theorem, Euler's Theorem in modular arithmetic.
- c) What is significance modeling and coding in data compression?
- d) Illustrate worst case in LZ-77 dictionary compression technique
- e) What are the measures of performances for lossy and lossless compression techniques

Q2. a) A source with alphabet $A=\{a,b,c,d,e\}$ with probabilities $P=\{0.2, 0.4, 0.2, 0.1, 0.1\}$ respectively calculate standard Huffman code, average code word length and draw binary tree

10

b) Explain Diffie Hellman Key exchange with the help of an example.

10

Q3. a) Explain RSA algorithm in detail and discuss attacks on RSA

10

b) Explain Arithmetic coding Tag generation using a suitable example

10

Q4 a) Explain Triple DES with two keys and 'Meet in the Middle Attack'

10

b) Explain Standard JPEG with neat diagram, what are the advantages of JPEG 2000 over standard JPEG? Justify use of DCT in JPEG

10

Q5 a) Explain Frequency and Temporal masking with respect to audio compression. Also explain how MP3 encoder works

10

b) What are digital signatures? Explain any one technique in detail.

10

Q6. Write short notes on any two

20

- a) MPEG video compression standard
- b) Elliptic Curve Cryptography
- c) Fire walls, Intruders and viruses
- d) Adaptive Huffman Coding

Time: 3 Hours

Marks: 80

Note:

1. Question No.1 is compulsory.
2. Solve any three from the remaining questions.
3. Assume suitable data wherever it is necessary.

1. Answer any four

20

- (a) Can two different images have the same histogram? Justify your answer.
- (b) What are the advantages of wiener filer over an inverse filter and when will wiener filter reduce to inverse filter.
- (c) What is hit-or-miss transformation? Explain in brief.
- (d) Justify Discrete Cosine Transform is real and orthogonal.
- (e) Explain the basics of sampling the video signals.

2 (a) Explain averaging filter used for enhancement of images? Filter the following image using a 3x3 neighborhood averaging by assuming (a) zero padding and (b) pixel replication.

10

1	2	3	2
4	2	5	1
1	2	6	3
2	4	6	7

(b) Discuss the different filters used in frequency domain filtering. Explain the ringing effect in ideal low pass and high pass filters.

10

3 (a) Prove the separable and spatial shift property of Fourier transform.

10

(b) Compute the 2D DFT and IDFT of the 4x4 gray scale image $f(m, n)$ given below .

10

1	2	3	4
5	6	7	8
1	2	3	4
5	6	7	8

- 4 (a) Explain opening and closing operations used for morphological image processing. Apply opening and closing operations the following image using the given structuring element. 10

0	1	1	0
1	0	0	1
1	0	0	1
0	1	1	0

0	1	0
1	1	1
0	1	0

- (b) Find the minimum cost path for edge linking using graph theoretical technique for the given image. Show the cost of all the paths on the graph. 10

5	6	1
6	7	0
7	1	3

- 5 (a) Explain the wiener filter used for restoration of degraded images. 10
 (b) Explain in detail block based motion estimation techniques for video signals. 10

6. Write short notes on (Any three) 20

- (a) Adaptive median filter
- (b) Discrete Cosine Transform
- (c) Adjacency, connectivity of pixels
- (d) Region filling

1. Question No. 1 is compulsory.
2. Out of remaining questions, attempt any three questions.
3. Assume suitable additional data if required.
4. Figures in brackets on the right hand side indicate full marks.

- Q.1. (A) Write a short note on TRAPATT. (05)
 (B) Write a short note on high electron mobility transistors. (05)
 (C) Match a load impedance $Z_L = 60 - j80$ to a 50Ω line using a double stub tuner. The stubs are open circuited and are spaced $\lambda/8$ apart. The match frequency is 2 GHz. (10)
- Q.2. (A) With a neat functional diagram explain the working principle of Cylindrical Magnetron. (10)
 (B) Derive equation for phase velocity, cutoff frequency, cutoff wavelength and field equations for rectangular waveguide. (10)
- Q.3. (A) Explain any one bio-medical application using microwave. (10)
 (B) Explain the working of a negative resistance parametric amplifier. (10)
- Q.4. (A) What is the importance of beam coupling coefficient? Derive the equation of velocity modulation in klystron. (10)
 (B) Given the circuit shown in Fig. 4(B), design a lumped element matching network at 60 MHz that would transform Load impedance $Z_L = 100 - j25 \Omega$ into an input impedance of $Z = 25 + j15 \Omega$. Take $Z_0 = 50 \Omega$. (10)

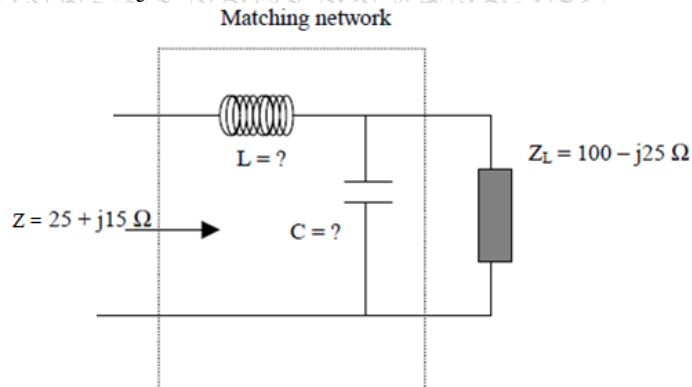

Fig. 4(B)

- Q.5. (A) What is meant by RADAR range? Derive the equation for Radar range in terms of the noise figure. (10)
 (B) Radar operating at 1.5 GHz uses a peak pulse power of 2.5 MW and has a range of 100 nmi for objects whose radar cross section is 1 m^2 . If the minimum receivable power of the receiver is 2×10^{-13} Watt, what is the smallest diameter of the antenna reflector could have assuming it to be a full paraboloid with $\eta = 0.65$. (10)
- Q.6. Write a short note on following:
- (A) Gunn diode. (07)
 (B) Hybrid Ring. (07)
 (C) Instrument landing system. (06)
- *****

(3 Hours)**[Total marks: 80]****Note:**

- 1) Question no. 1 is compulsory.
- 2) Write any three questions from remaining five questions.
- 3) Assume suitable data if necessary.

Q.1 Answer any four**(20)**

- a) With respect to trunking theory describe following terms:
 - i) Busy Hour
 - ii) Traffic intensity A
 - iii) Average call arrival rate H
 - iv) Average call duration
 - v) Trunking efficiency & GoS
- b) Calculate gross data rate of GSM
- c) Discuss IS 95 CDMA forward channels.
- d) Which modulation techniques are used for uplink and downlink in LTE and discuss their advantages.
- e) List out advantages of SDR in communication.

Q.2**(20)**

- a) There are six co channel cells in the first tier, and all of them are at the same distance from the mobile ($N=7$), If a signal to interference ratio of 15dB is required for satisfactory forward channel performance of a cellular system, Calculate frequency reuse factor and cluster size that should be used for maximum capacity if path loss exponent is $n=3$ and $n=4$.
- b) Why Propagation Path Loss is one of the major parameters of interest in analysis of radio wave propagation for mobile communication? Discuss free space propagation Model and derive an expression for the received power.

Q.3**(20)**

- a) Compare and contrast WCDMA with CDMAone for various performance measures.
- b) GSM provides 'on the air privacy' security feature during voice calls. Justify.

Q.4**(20)**

- a) What are the reasons for intra-cell handover? Discuss different possible handover scenarios in GSM?
- b) Compare GPRS and EDGE with technical and functional differences. How higher data rates are achieved in EDGE?

Q.5 (20)

- a) Discuss the main elements of the LTE-SAE network of EPC (Evolved Packet Controller).
- b) Discuss cell search and synchronization in 3G

Q.6 (20)

- a) How mapping of channels is achieved with layers in LTE protocol layers?
- b) What is Multi antenna technology? Explain MIMO with its advantages and applications

(3 Hours)

- N.B: (1) Questions No.1 is compulsory.
 (2) Solve any three questions out of remaining
 (3) Draw neat labeled diagram whenever necessary
 (4) Assume suitable data if necessary

- Q1. Answer any 4 questions from the given questions: 5x4
- Describe fuzzy inference system with neat block diagram.
 - What is the role of Dendrites, Soma and Axon of biological neuron that led to the concept of artificial neuron? Brief with a diagram.
 - Discuss how momentum factor accelerates training of perceptron neural network.
 - Explain memorization issue in neural networks. How to avoid memorization and get generalization?
 - What is λ -cut set? Brief with an example

- Q2.a. If one of the weights is removed from Multilayer Perceptron Neural Network (MLP NN) the functionality of the network is highly affected whereas Radial Basis Function Neural Network (RBF NN) functionality is not significantly affected. Justify. Also, discuss how pattern separation in RBF NN happens by placing hyper-ellipsoids and hyper-sphere whereas in MLP NN it happens due to hyper-planes. 8

- b. What are the merits of fuzzy controllers over conventional controllers? 4

- c. i) Using max-min composition find relation between R and S 8

$$R = \begin{matrix} & y1 & y2 & y3 \\ x1 & \begin{bmatrix} 1 & 1 & 0 \end{bmatrix} \\ x2 & \begin{bmatrix} 0 & 0 & 1 \end{bmatrix} \\ x3 & \begin{bmatrix} 0 & 1 & 0 \end{bmatrix} \end{matrix}$$

$$S = \begin{matrix} & z1 & z2 \\ x1 & \begin{bmatrix} 0 & 1 \end{bmatrix} \\ x2 & \begin{bmatrix} 1 & 0 \end{bmatrix} \\ x3 & \begin{bmatrix} 1 & 1 \end{bmatrix} \end{matrix}$$

ii) Consider the following fuzzy sets

$$A = \left\{ \frac{0.8}{10} + \frac{0.3}{15} + \frac{0.6}{20} + \frac{0.2}{25} \right\}$$

$$B = \left\{ \frac{0.4}{10} + \frac{0.2}{15} + \frac{0.9}{20} + \frac{0.1}{25} \right\}$$

Calculate the Demorgan's law
 $\overline{A \cup B} = \overline{A} \cap \overline{B}$ and $\overline{A \cap B} = \overline{A} \cup \overline{B}$

- Q3.a. Describe any two methods for feature extraction of handwritten characters. Also, explain handwritten characters classification using supervised neural network? 10
- b. Describe the application of fuzzy logic for following image processing operations: 10
- a) Image Contrast Enhancement
 - b) Image Smoothing
- Q4.a Explain pattern recovery using discrete Hopfield network. 10
- b. Explain Kohonen self-organizing network for pattern clustering. Also, explain its learning algorithm. 10
- Q5.a Explain the purpose of de-fuzzification process? Discuss any three techniques for de-fuzzification. 10
- b. Explain with neat diagram the radial basis function neural network for function approximation. 10
- Q6.a. Describe with architecture Learning Vector Quantization (LVQ) network with suitable diagram and the flow chart for pattern classification. 10
- b. What is the role of a) weights b) bias c) activation function d) training data set and e) validation data sets in the context of neural networks 10
-

(3 Hours)

[Total Marks: 80]

- N.B.** (1) **Question No.1** is compulsory
 (2) **Attempt** any **three** questions from remaining questions
 (3) **Figures** to right indicate **full** marks

1. a) Explain the advantages of OTN over SONET. **05**
 b) Compare Intermodal and Intramodal Dispersion **05**
 c) Define Critical Angle, Acceptance Angle and Numerical Aperture and quantum efficiency **05**
 d) What is fiber bragg gratings? Give its applications. **05**
2. a) Explain the Linear and Nonlinear scattering in optical fiber **10**
 b) A typical relative refractive index difference for an optical fiber designed for long distance transmission is 1%. Estimate NA and solid acceptance angle in the air for the fiber when the core index is 1.46. Further calculate the critical angle at the core cladding interface within the fiber. It may be assumed that the concept of geometric optics hold for the fiber **10**
3. a) Explain modified chemical vapour phase deposition method of fiber fabrication. **10**
 b) What is optical amplifier? Explain in brief its different types **10**
4. a) Explain in detail working principle of Avalanche photodetector. Explain its merits and demerits **10**
 b) Explain SONET architecture in detail. Draw the Frame of SONET and determine its basic rate **10**
5. a) Explain in Bit interleaving and packet interleaving techniques used in OTDM **10**
 b) Explain in brief different types of PON architecture. **10**
6. Write short notes on any two **20**
 - a) Optical safety
 - b) Wavelength stabilization
 - c) Crosstalk in optical system
 - d) Network Management functions.
